

ENERGIZER 364

ZEROMERCURY

SILVER OXIDE



Industry Standard Dimensions

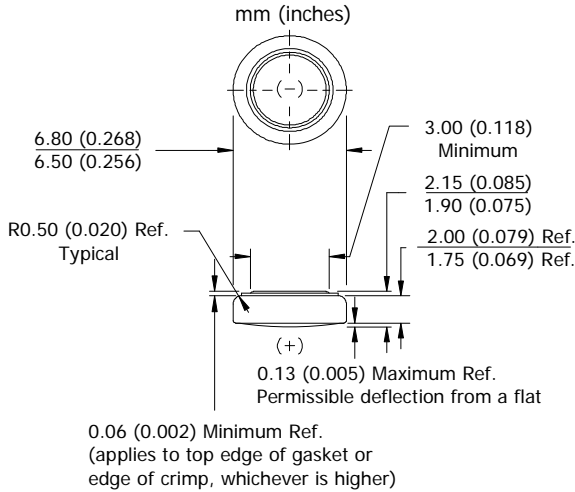

DESIGNED FOR USE ON CONTINUOUS LOW DRAIN
HIGH PULSE ON DEMAND

Specifications

- Chemical System:** Silver Oxide (Zn/Ag₂O)
- Designation:** ANSI-1175SO, IEC-SR60
- Nominal Voltage:** 1.55 Volts
- Typical Capacity:** 18 mAh* (to 1.2 volts)
- Capacity Test:** 100K ohm continuous drain at 21°C
- Typical Weight:** 0.37 grams (0.012 oz.)
- Typical Volume:** 0.08 cubic centimeters (0.005 cubic inch)
- Impedance (40 Hz):** 5 to 15 ohms

* Varies according to the applied load, temperature, and cutoff voltage.

Cross Section

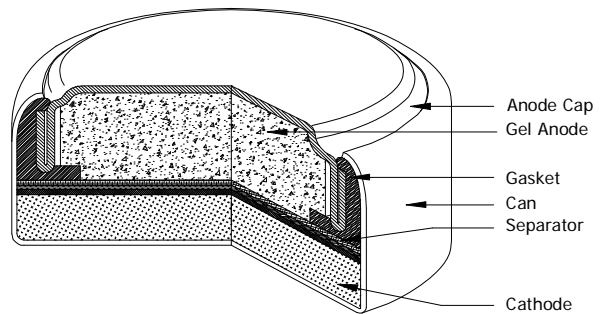

Typical Discharge Characteristics

Typical Performance at 21°C (70°F)

Schedule: Continuous
Typical Drain @1.47V:
0.022 milliamperes
Load: 68K ohm

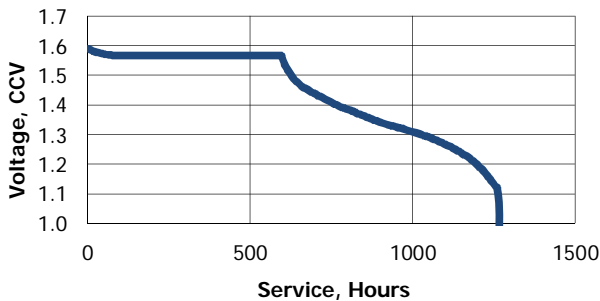

Schedule	Typical Drains at 1.47V (milliamperes)	Load (ohm)	Cutoff (hours)
Continuous	0.015	100K	1,200

Temperature Characteristics

Typical Performance at Low Discharge Rates

Service Effects

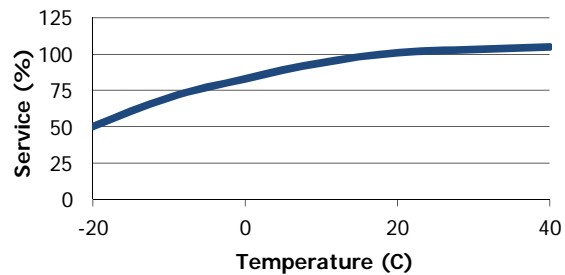

Storage Effects

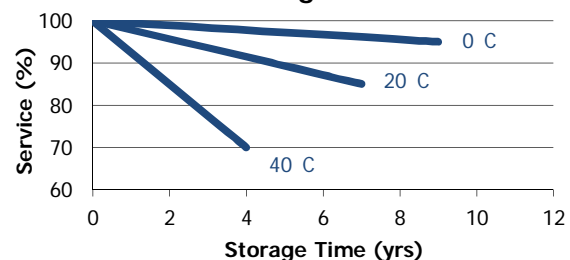

Important Notice

This datasheet contains typical information specific to products manufactured at the time of its publication.

©Energizer Holdings, Inc. - Contents herein do not constitute a warranty.